

PRODUCT NO.
10031193-001LF
10031193-002LF

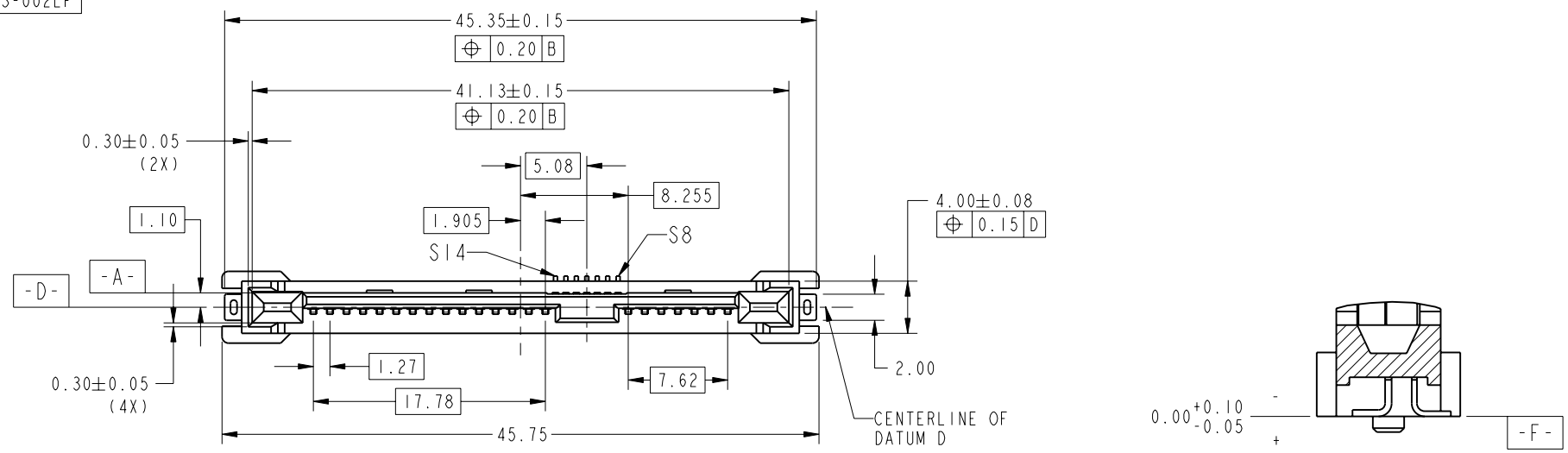

DETAIL A
SCALE 4:1

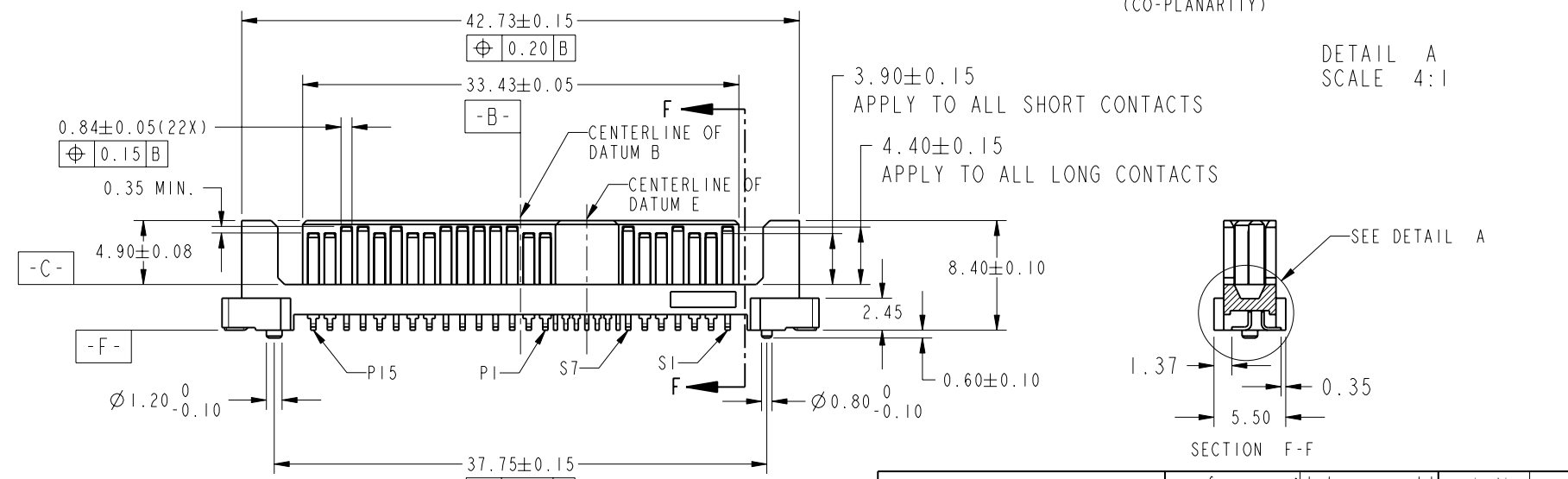

SECTION F-F



Copyright FCI.

rev	ecn no	dr	date
A	S04-0178	SHT	2004/08/19
B	S05-0368	HKL	2005/12/29
C	S06-0077	HKL	2006/03/13
D	S06-0182	HKL	2006/05/26
E	S06-0276	HKL	2006/08/18
F	S07-0301	HKL	2007-09-05
-	-	-	-

www.fciconnect.com		surface ASME Y14.5	tolerance std ASME Y14.5	projection MM
		TOLERANCES UNLESS OTHERWISE SPECIFIED		
Dr	SH TAN	2004/08/19	ANGULAR	size A4
Eng	HK LIM	2007-09-05	LINEAR	Scale 2:1
Chr	HK LIM	2007-09-05	0° ±2°	ECN S07-0301
Appr	JOEY NG	2007-09-05	Product family	Spec ref
SAS PLUG VERTICAL SMT ASSY			dwg no 10031193	Rev. F
catalog no			CUSTOMER	sheet 1 of 3

REV E - 2006-03-28

PRODUCT NO.
SEE TABLE

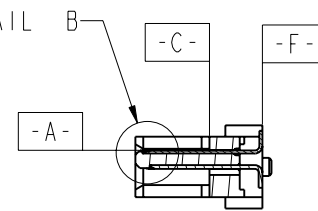
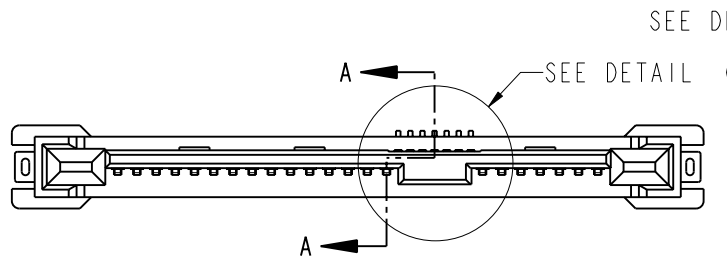
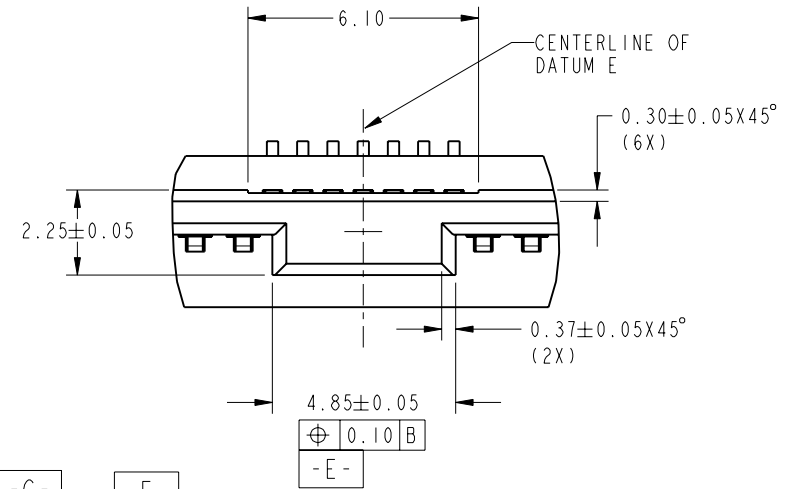
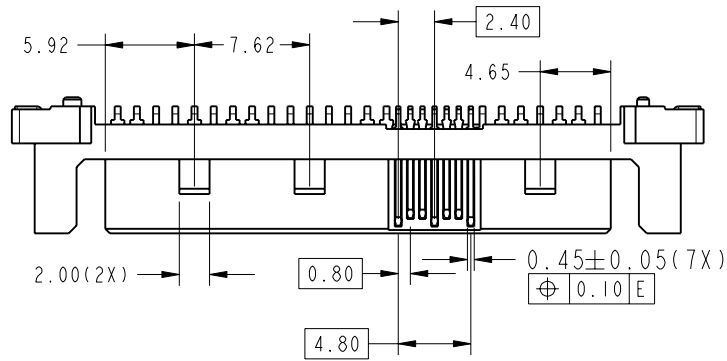

DETAIL G
SCALE 5:1

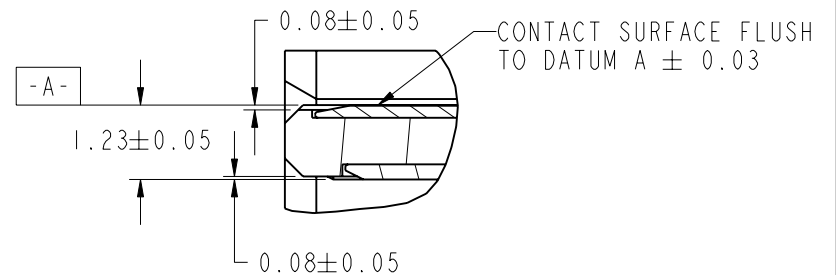
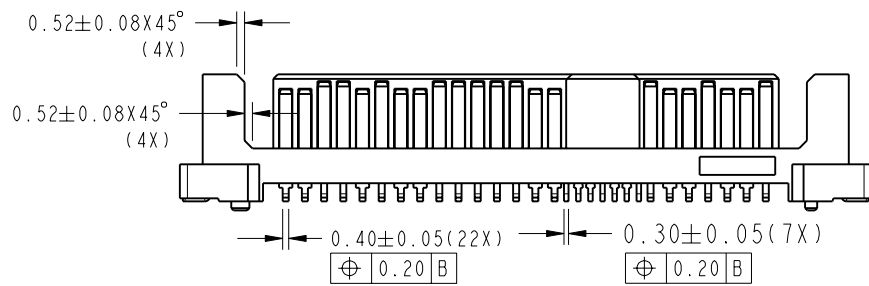

DETAIL B
SCALE 8:1



Copyright FCI.

FCI	part no	SAS PLUG	dwg no	10031193	Rev.	F
	title	VERTICAL SMT ASSY	customer	CUSTOMER	sheet 2 of 3	
	catalog no					

PRODUCT NO.	WITH PICK-UP CAP	PACKAGING	PLATING SPEC.
10031193-001LF/-002LF	NO	TRAY	-001LF REFER TO NOTE 2A
10031193-001CLF/-002CLF	YES		-002LF REFER TO NOTE 2B
10031193-001C-TRLF/-002C-TRLF		TAPE & REEL	

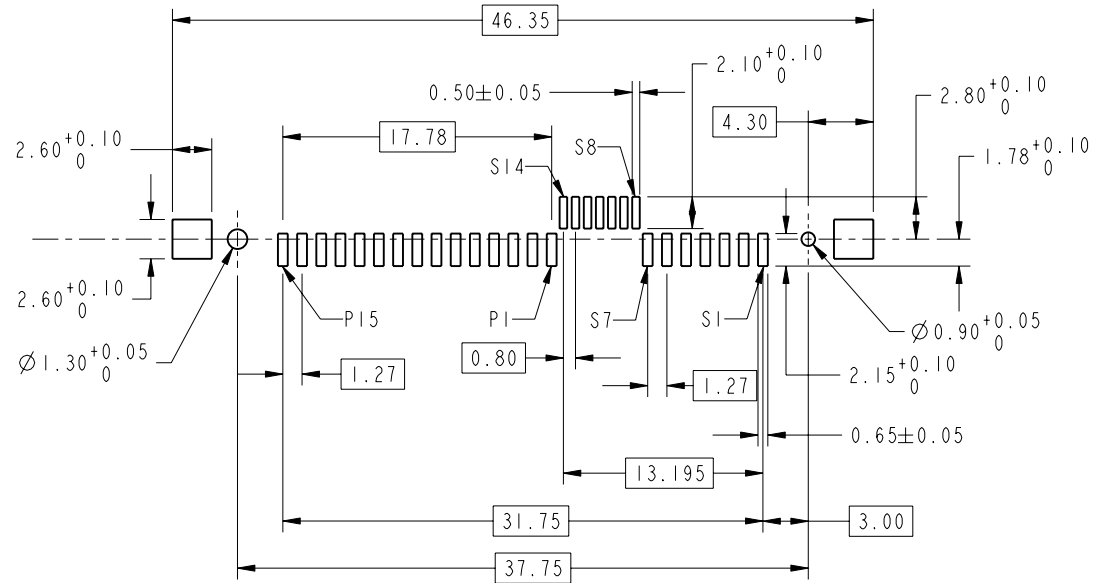
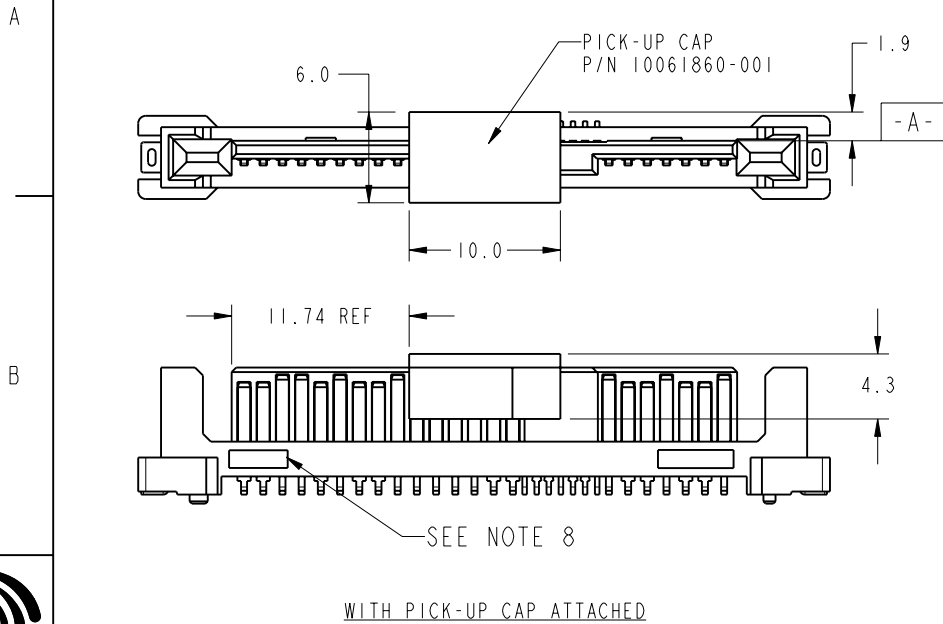

RECOMMENDED SOLDER PAD LAYOUT

NOTES:-

- MATERIAL:
HOUSING: HIGH TEMPERATURE PLASTIC, BLACK, UL94V-0
CONTACT: COPPER ALLOY
HOLD DOWN: COPPER ALLOY
PICK-UP CAP: HIGH TEMPERATURE PLASTIC, BLACK, UL94V-0
- FINISH:
CONTACT: 1.27um MIN. NICKEL UNDERPLATE OVERALL,
1.91um MIN. 100% MATTE TIN ON SOLDER TAIL,
A) 0.76um MIN. GOLD ON CONTACT AREA
B) 0.76um MIN. GXT™ ON CONTACT AREA
HOLD DOWN: 2.54um MIN. 100% MATTE TIN OVER 1.27um MIN. NICKEL UNDERPLATE
- THIS PRODUCT MEETS EUROPEAN UNION DIRECTIVES AND OTHER COUNTRY REGULATIONS AS DESCRIBED IN GS-22-008
- THE HOUSING WILL WITHSTAND EXPOSURE TO 260°C PEAK TEMPERATURE FOR 10 SECONDS IN A CONVECTION, INFRA-RED OR VAPOR PHASE REFLOW OVEN
- PART WITH PICK-UP CAP, P/N XXXXXXXX-XXXCLF
- FOR TAPE & REEL PACKAGING, P/N XXXXXXXX-XXXC-TRLF
- ASSY DIMENSIONS WITH REFERENCE TO SFF-8482 REV 1.7
- THE PART SHALL HAVE "FCI" ID AND CAVITY NUMBER SHOWN IN THE APPROXIMATE LOCATION

Copyright FCI.

FCI	part no	SAS PLUG	dwg no	10031193	Rev.	F
	catalog no	VERTICAL SMT ASSY	CUSTOMER	sheet 3 of 3		